

(bottom view)

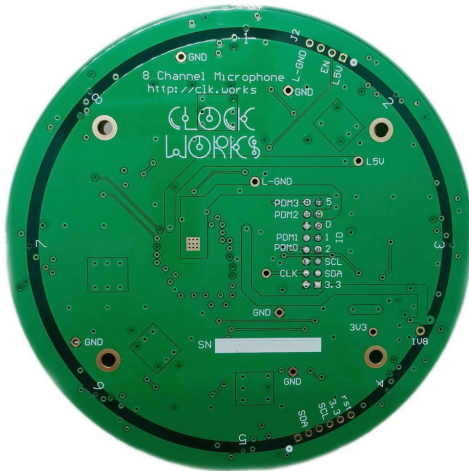

(top view)

SUPPORTS

ANALOG DEVICES



Signal Processing

A²B[®] 8 CHANNEL MICROPHONE ARRAY

Summary

- Off the shelf board set for A²B[®] interfacing to microphone arrays.
- Microphone board is separate from rest of system to allow easy customization of microphone array geometry and microphone count.
- ADAU7118 PDM to I²S interface can be controlled over A²B to adjust channel configurations and enable filter features.
- A²B section based on Analog Devices newest AD2428 A²B device
- 8 RGB LEDs for *blinkerlights* features

Introduction

Analog Devices' A²B system allows up to thirty two 24 bit 48 kHz data (audio) channels to be carried bidirectionally over twisted pair wire between multiple nodes. Supporting up to 15 meters of cable between nodes it provides a low cost way to expand audio processing systems.

Clockwork's A²B microphone array is intended for users developing speech processing systems in complex audio environments that may need multiple distributed arrays of microphones to achieve system performance goals.

A²B's low, 2 sample deterministic latency makes sophisticated noise cancellation and speaker tracking possible even when the sub arrays are several meters apart.

System details

There are three boards in the system kit:

- Microphone board (PDM output)
- PDM to I²S adapter board
- Clockworks A²B module

A²B 8 channel microphone system specifications

- A²B
 - Device: Analog Devices AD2428
 - EEPROM 24FC256 (32 kbyte)
 - A²B configuration: locally powered slave with downstream network power output
- PDM to I²S conversion
 - Analog Devices ADAU7118.
 - Default configuration: 4 stereo PDM inputs (64x default) with 48 kHz sample rate. Single 8 channel 32 bit TDM output to A²B .
- Microphones
 - Eight Infineon IM68D130. 69dB(A) SNR,<1% total harmonic distortions up to 128dB SPL, 28 Hz to 20 kHz (+/- 3 dB)
 - LED controller: TI LP5024 24 channel controller
- Diameter: PCB 100mm. Microphones 90mm (evenly space every 45 degrees).
- Height: 36mm (boards stack with 11mm x 3 spacers), component side down.
- Power 9VDC (9.6 max). 2.1mm center positive barrel connector or screw terminals. Kit supplied with AC adapter.
- Power draw: 50 mA (typical) + LED power (200 mA LED max in default setup)

Developer features

The board is designed to be operated over the A²B link. There is a User LED and pushbutton on the adapter board that can be controlled/monitored over A²B, as well as the 8 RGB LEDs on the microphone board. An EEPROM is included to allow emulation of applications where local node storage is used to hold settings, note there is no controller on this board, all peripheral programming must be done by the host.

A 6 pin .1" MTA style connector that conforms to the Clockworks standard AUX CTRL connector pinout and provides access to the I²C bus is available on both the microphone PCB and the adapter PCB.

Sample I²C scripts and settings information is provided along with a Sigma Studio schematic. The board does not include array processing software as it's intended as a development platform.

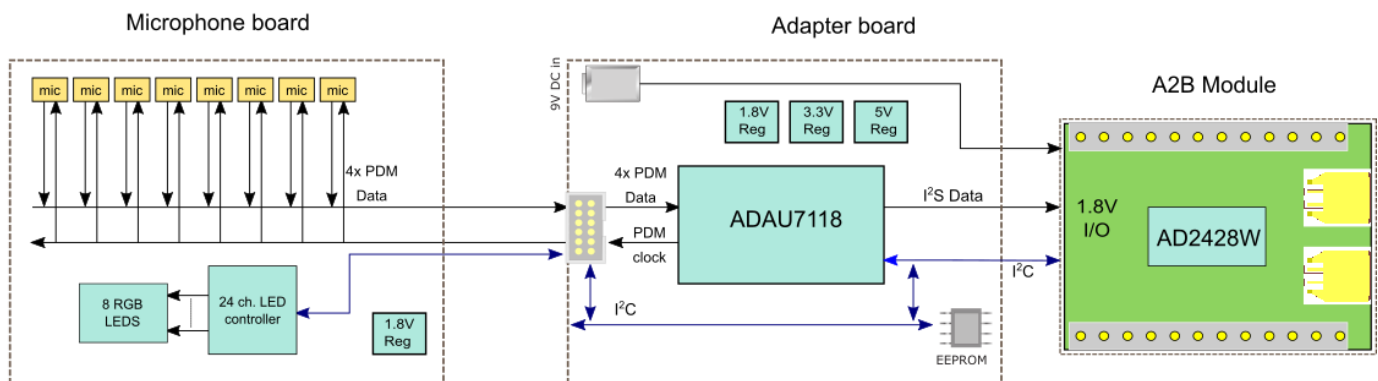

SYSTEM BLOCK DIAGRAM

Software support

Analog Devices' A²B SDK is required to use this board and must be obtained directly from them. The SDK includes an add-on package for using Sigma Studio (available without charge from ADI) for A²B network configuration. Programming of the A²B master requires purchase of the USBi (part number EVAL-ADUSB2EBZ) Sigma DSP emulator from Analog Devices.

A²B requires one master node. ADI offers a number of options for the master node. The ADI SHARC Audio Module provides the latest ARM with dual SHARC+ cores (SC589) and A²B and makes an excellent platform for developing the signal processing applications that typically go with microphone arrays. ADI's EVAL-AD2428WB1BZ can also be used as the bus master.

Ordering information

Detailed order codes are listed on the last page. For OEM quantities of modules please contact Clockworks for price and lead time. EVM kits and small quantities of modules are normally available from stock.

The kit documentation package includes schematic (pdf and Altium source), BOM, and gerbers for the microphone and adapter PCBs. A .STEP file for the microphone and adapter PCB are included to facilitate design of your own microphone board.

Custom microphone boards

Most applications will want a different microphone configuration. For customers that don't have the resources for designing their own microphone boards Clockworks offers two fixed price options for custom microphone board layouts for use with this platform. The basic option just changes the quantity and/or location of the microphones. The advanced option includes changing the microphone part. Offered at a fixed price, delivery of 5 samples is typically 4 weeks from receipt of payment.

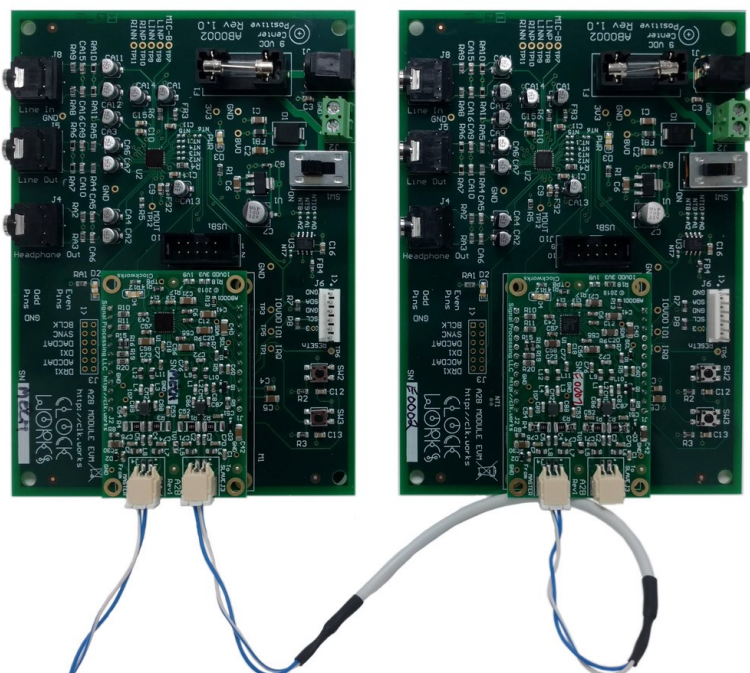

Analog Devices' A²B system operates as a daisy chain. One connector is the upstream side that ultimately connects to the first (master) device. The second connector connects downstream towards the last (slave) device in the daisy chain. Up to 9 modules may be daisy chained with up to 15m between nodes and total wire length of 40m.

Clockworks' A²B module offers a convenient way to develop A²B applications as it breaks out A²B to two 12 pin .1" connectors. The A²B module is a direct copy of ADI's reference design, and can be purchased with the EVM kit shown in the photo here.

Please see the Clockworks website for more information about the module and other companion A²B products.

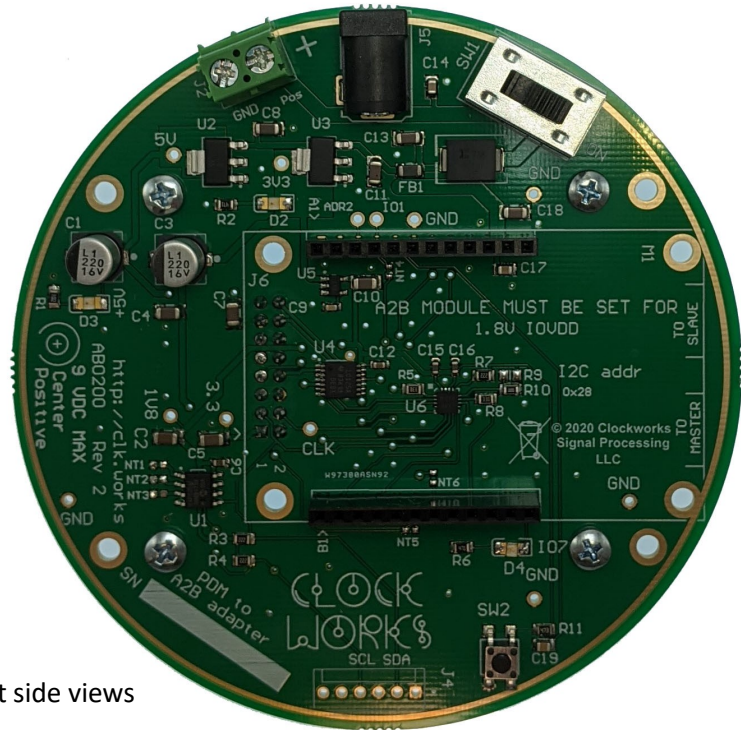
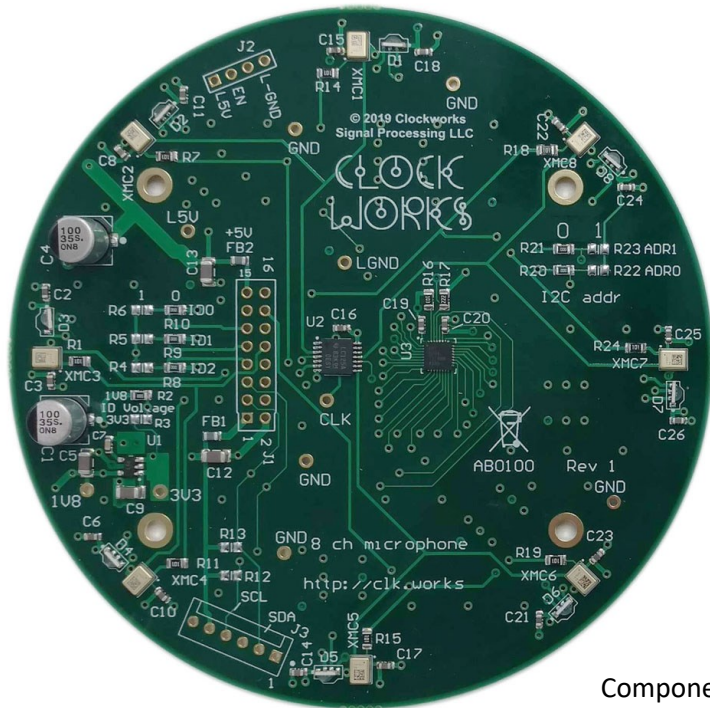

Component side views

Microphone Board (left) and Adapter Board (right, without A²B module)

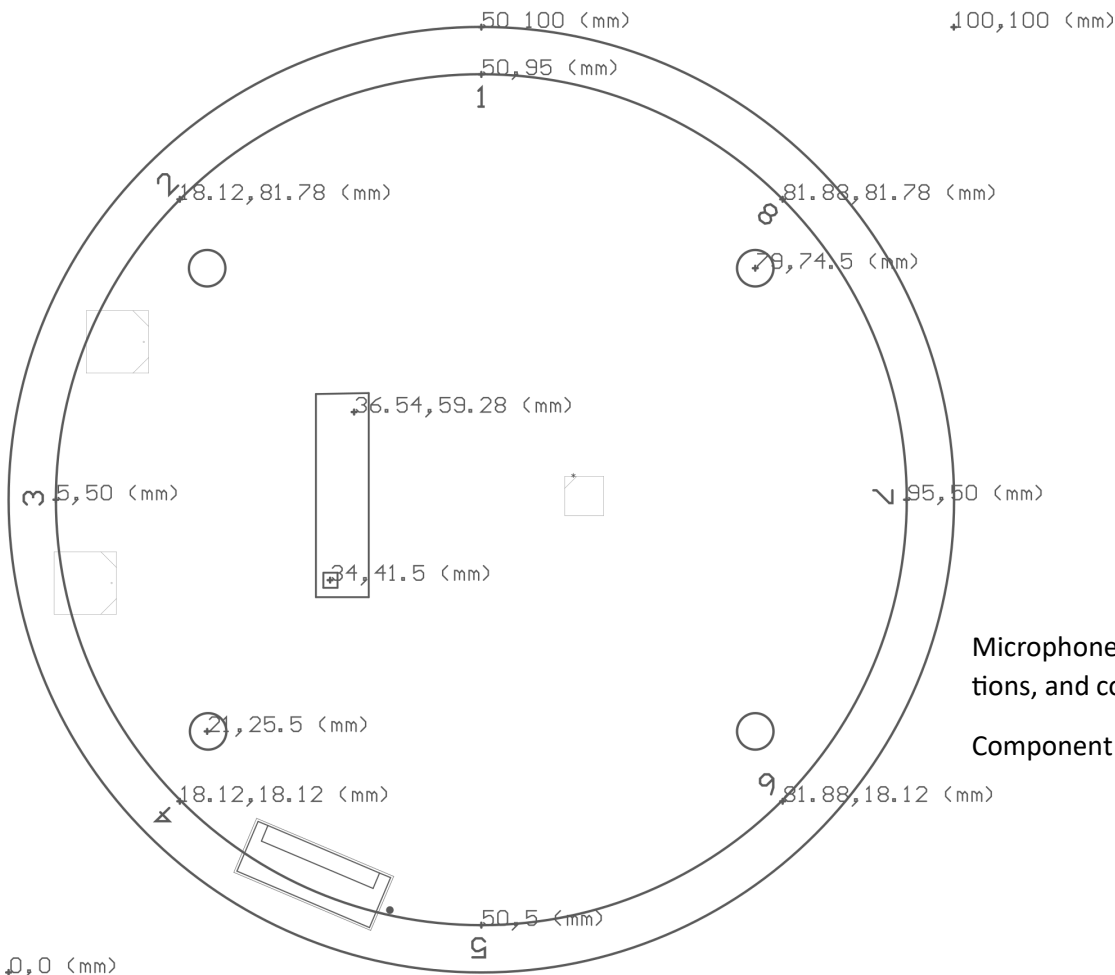

Microphone board size, mic locations, and connector location.

Component side view.

Microphone connector pinout

Pin	Name	Notes
1	3V3	Power (I/O voltages are 1.8V)
2	GND	
3	SDA	I2C data
4	PDM_C LK	PDM clock input
5	SCL	I2C clock
6	GND	
7	ID2	
8	PDM_0	PDM 0 output (mics 1 & 2)
9	ID1	
10	PDM_1	PDM 1 output (mics 3 & 4)
11	ID0	
12	GND	
13	L5V0	LED supply, 5V
14	PDM_2	PDM 2 output (mics 5 & 6)
15	L_GND	Ground from LEDs
16	PDM_3	PDM 3 output (mics 7 & 8)

Order codes

- A2B01-S A²B to I²S module, single. Note: Must be configured for 1.8V I/O operation, normal default is 3.3V I/O
- AB0200 8 channel microphone board (PDM output)
- AB0100 PDM to I2S adapter board
- EVMA2BMIC-NA Three board stack (A2BMIC-08A, A2BPDM01, A2B01-S), 9V supply with universal AC input supply (NEMA 1-15 blade), documentation package.
- EVMA2BMIC-INT As above but with universal AC input supply with multi-blade kit (NA, EU,UK,AUS,CN)
- CB-EVMA2BMIC Quantity 5 EVMA2BMIC kits (-NA or -INT supplies included) with custom microphone board: modified microphone count and location only (no LEDs). 4 week delivery for first article typical.

Contact Clockworks for other custom options.

Development tools are not tested for FCC/CE emissions.

Modules may need to be installed in appropriately shielded user supplied enclosure.

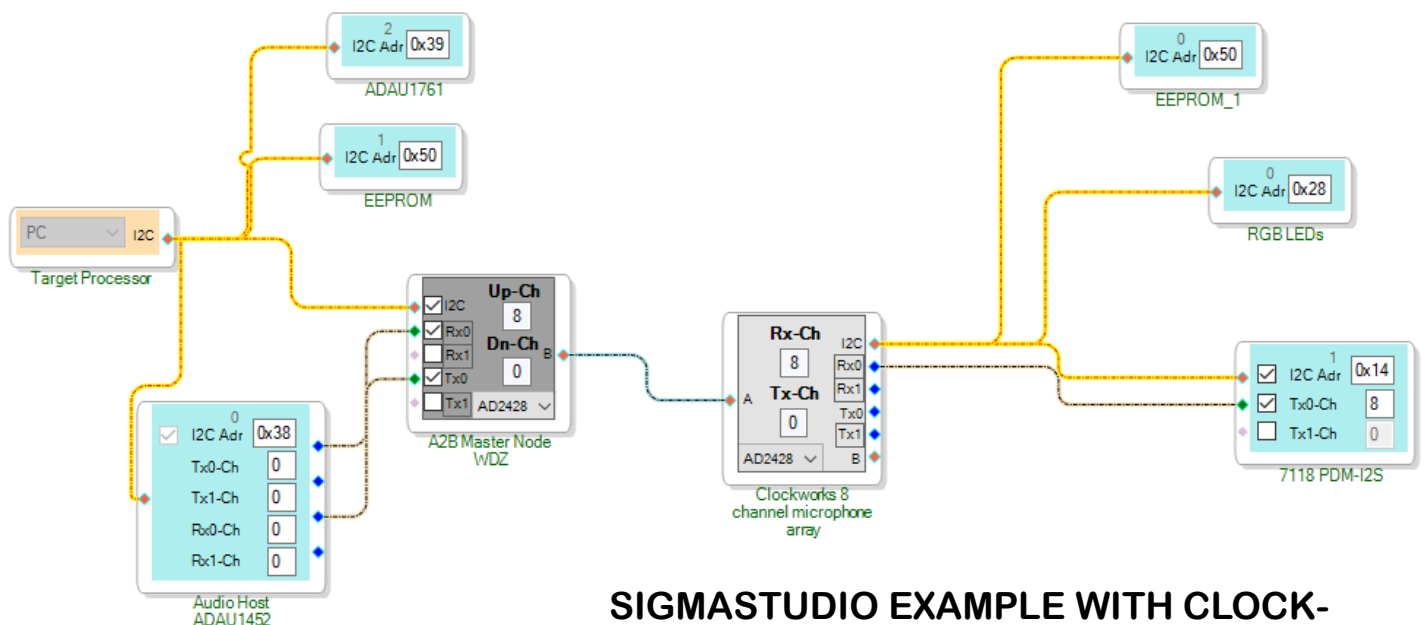

SIGMASTUDIO EXAMPLE WITH CLOCKWORKS A²B MICROPHONE NODE