

ANALOGBLOX™
TRIPLE OUTPUT POWER SUPPLY
ASSEMBLED SMT
-OR-
ASSEMBLED SMT & PARTS
KIT
PWRK01

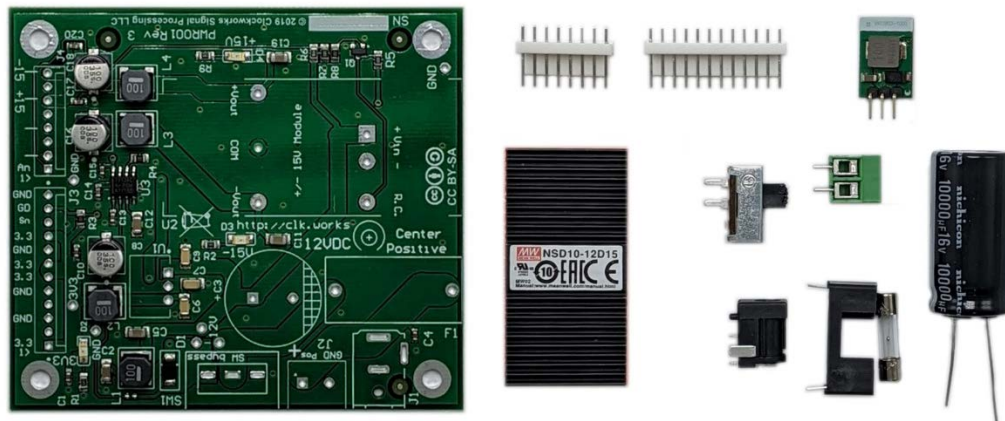

For Revision 3 hardware

Rev 1.0

30-Mar-2021

CLOCKWORKS
Signal Processing

<http://clk.works/>

Copyright 2020 Clockworks Signal Processing LLC

1. TABLE OF CONTENTS

1	Introduction	3
1.1	Module options.....	4
1.1.1	Cables	4
1.1.2	Input 12V supply.....	4
1.2	How Supplied	4
1.2.1	Through hole parts list	5
2	Assemble the module.....	6
2.1	Part locations.....	7
3	Testing	7

Attachment: User Guide, Schematic, 3D pdf.

SignalBlox, AnalogBlox, and DigitalBlox are trademarks of Clockworks Signal Processing LLC and may not be used without permission.

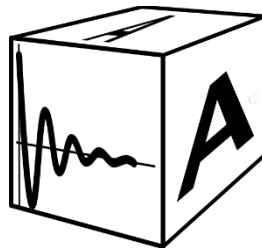

1 INTRODUCTION

This document is for the kit versions of Clockworks triple output PWR001 module. This kit is an intermediate level build project. It does not require assembly of SMT components, but the builder should:

- Be familiar with through hole component soldering
- Own an appropriate soldering iron and tools and have an ESD safe work area
- Understanding basic electronic component types and how to orient them correctly, particularly for polarized components.
- Own a voltmeter and understand basic diagnostics in case something goes wrong

Fully assembled and tested [boards are available from Clockworks](#), this kit is provided as an option for those that are interested in building simple electronics projects.

Included with this document is the User Guide for the PWR001, along with the schematic and a 3D PDF to assist you in building the board.

Details about the power supply design and its initial testing can be found in the [TechNotes section of the Clockworks](#) website.

For more details on the power supply module please see the User Guide.

When completed your board will look like this:



Figure 1 PWR001 module

1.1 MODULE OPTIONS

It's possible to use other voltage regulators with this design. If that is done it is suggested you rewire the output connectors so that the a higher voltage doesn't appear on a given power pin than what it normally would supply. Failure to do this could lead to the release of the magic smoke if you connected your custom supply to standard Clockwork's products.

In other words don't put +5 on the 3.3 pin, and don't put anything more than +/-5 on those pins.

1.1.1 CABLES

The output connectors are standard MTA-100 style headers. The mating parts are low cost and can be assembled with a simple hand tool. Clockworks also offers cable sets for sale.



1.1.2 INPUT 12V SUPPLY

The supplies noise performance can be impacted by the supply used to create the 12V input. The large holdup capacitor can also give some supplies a difficulty in startup, they think they are faulted.

As supply vendors change models and designs all the time there's no specific recommendation made here. Check the Clockworks product page for information about what model(s) of supplies we sue in the full kit versions.

1.2 HOW SUPPLIED

The PWRK01 is supplied in two standard configurations:

- PWR001 board with SMT components installed
- PWR001 board with SMT components installed and a kit of all of the through hole parts

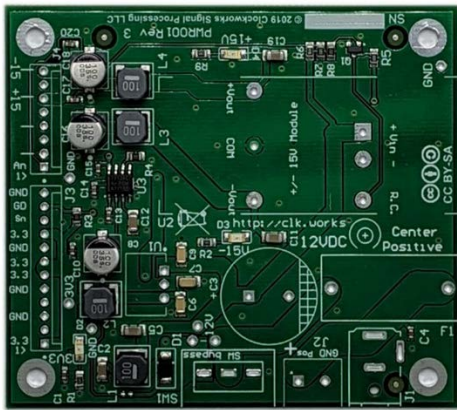

Figure 2 PWR001 with SMT only parts

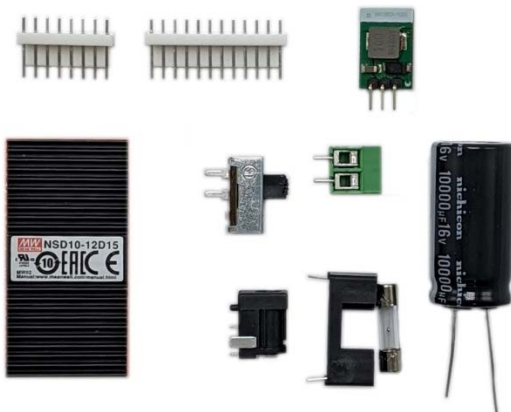

Figure 3 PWR001 through hole parts

1.2.1 THROUGH HOLE PARTS LIST

The schematic can also be clicked on for more information about the parts. While the parts are all somewhat generic, mechanical considerations make it difficult to substitute functionally equivalent parts.

Comment	Description	Value	Voltage	Designator	Manufacturer	Part Number
10000 uF	TH 7.5mm 18x40 10000uF	10000 uF	25V	C3	IC	109CKSo25M
DIG PWR	Header MTA-100; 12; polarized 250 VAC; Polyester; Tin; Copper Alloy; Tin	12M		J3	TE Connectivity	1-640454-2
ANA PWR	Header, MTA-100; 8; polarized 250 VAC; Polyester; Tin; Copper Alloy; Tin	8M		J4	TE Connectivity	640454-8
PJ-050AH	CUI 2.1x5.5mm barrel connector			J1	CUI	PJ-050AH
1935161	Conn Terminal Blocks 2 POS 5mm Solder ST Thru-Hole 16A			J2	Phoenix Contact	1935161
VXO7803-1000	3.3V 1A buck regulator CUI		3.3V	U1	CUI	VXO7803-1000
5x20mm fuse holder	5x20mm fuse holder			F1	Keystone	4527
fuse	1.6A SB 5x20 mm					
SPST slide	SPST slide			SW1	CW	GF-123-0054
12Vin +/- 15V out 10W	+/-15V 10W power module open frame			U2	Meanwell	NSD10-12D15

2 ASSEMBLE THE MODULE

The parts can be assembled in any method that you find convenient, though generally a lowest to tallest method works well for this board. A 3rd hand or similar is needed to hold connectors flush and parallel to the board.

The power switch has a small tab that tends to get in the way of seating the switch completely, it may require gentle persuasion to line up.

Pay attention to the orientation of the 3.3V regulator. So the pictures and/or the 3D drawing to compare against.

2.1 PART LOCATIONS

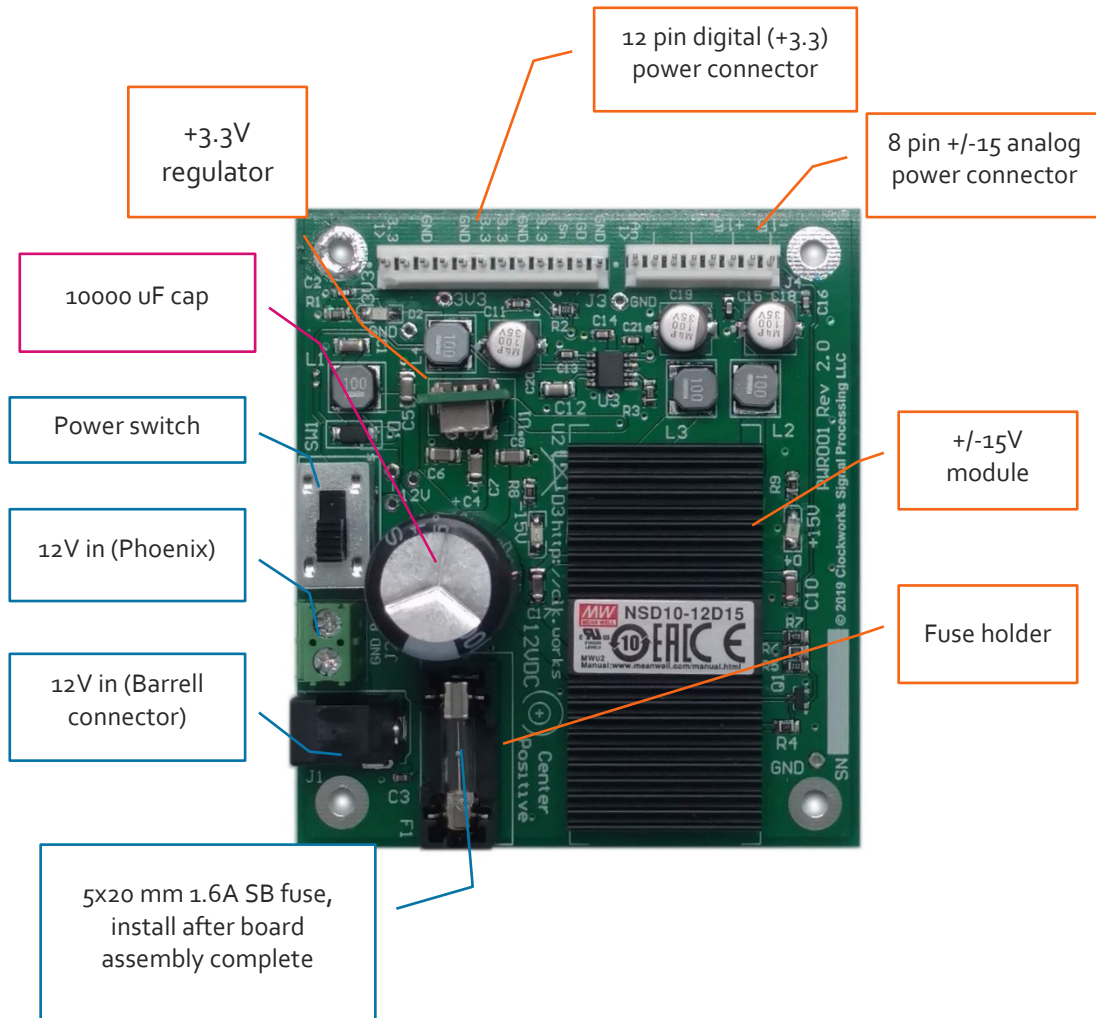

Figure 4 Board part locations for through-hole assembly

3 TESTING

PWR001 Triple Output Module kit Assembly Guide

Visually inspect the board for solder bridges, cold solder joints, and open solder joints.

Verify the polarity/installation of the 3.3 regulator and 10000 uF capacitor.

Things you'll need:

- 12 V power supply
- Jumper wire with female ends for .025 post
- Voltmeter
- Optional: load test fixture¹

Connect your 12V supply to the power input connector and turn the power switch on.

Check that the 3.3V supply is the correct voltage at the connector (12 pin, pins 1, 6, 7, 9) and that the Red LED for the 3.3V supply is illuminated.

Jumper pin 1 of the 8 pin analog supply connector to ground (pins 3, 5, or 7). The + and – 15V LEDs should turn on.

Measure the voltages on pin 6 (+15V) and pin 8 (-15V).

Optional: connect the supply to a load test fixture and verify voltages stay within regulator specifications at different load levels.

While testing all parts should remain cool; the switching regulators are efficient enough that they should never be so hot they can't be touched.

If you observe smoke, flame, or small thermonuclear reactions, please shut off the board immediately.

¹ If the correct voltages are observed with no load than there's very small likelihood of an issue under load. Clockworks always full tests supplies for in tolerance voltages under load, using the [passive multivoltage test fixture](#) that's available on the Clockworks website.

ANALOGBLOX™

TRIPLE OUTPUT POWER SUPPLY

PWR001



For Revision 2 hardware

Rev 3.0

30-Dec-2019

CLOCKWORKS
Signal Processing

<http://clk.works/>

Copyright 2019 Clockworks Signal Processing LLC

1. TABLE OF CONTENTS

1	Introduction	3
1.1	Module Description	4
1.2	How Supplied	4
1.3	Special versions	4
1.3.1	Input voltage range	5
1.3.2	Output voltage options	5
1.4	Software support	5
1.5	Input power requirements	6
2	Connector & Mechanical information	6
2.1	Input connectors	6
2.2	Output connectors	6
3	Regulator information	8
3.1	Meanwell NDS-10D15 (+/- 15V)	8
3.2	CUI VXO7803-1000 (3.3V)	9
4	Power sequencing	9
4.1	Mechanical	10
5	Design considerations	12
5.1	Measured noise	12
6	Getting started with the module	13
6.1	Other things	13
6.2	+/-15 supply noise	14

Attachment: Schematic.

SignalBlox, AnalogBlox, and DigitalBlox are trademarks of Clockworks Signal Processing LLC and may not be used without permission.

1 INTRODUCTION

The Clockworks PWR001 provides +/-15V 330 mA and 3.3 V 1 amp outputs for use in the AnalogBlox portion of a SignalBlox system. It is generic enough that it can be used in any general power supply application. It's powered by a 12 VDC input. One of its more unique features is the ability to signal loss of power and hold up the outputs for up to 10 msec after loss of primary input. This allows the system controller time to ramp down volume levels and engage output muting circuitry to minimize clicks and pops on unplanned power loss.

The module provides control of the +/-15V supplies to enable a host controller to enable analog supplies after the digital portion of the system is in a stable, operational state.

The supply has been designed to efficiently provide clean, low noise analog power without the need to use LDOs in the system design. Measurements performed during the design evaluation showed that analog audio systems using this supply can achieve SNR of better than 120 dB without resorting to local LDOs.



Figure 1 PWR001 module

1.1 MODULE DESCRIPTION

The PWR001 module is a SignalBlox standard sized 75mm x 85 mm module with two MTA-100 style connector headers for supply outputs and control. The pinouts are the same as those described in the SignalBlox System Configuration Guide.

One of its more unique features is the ability to signal loss of power and hold up the outputs for up to 10 msec after loss of primary input. This allows the system controller time to ramp down volume levels and engage output muting circuitry to minimize clicks and pops on unplanned power loss.

Outputs are:

- +3.3 at 1 amp (always on output for powering standby/host controller)
- +/-15V at 330 mA, intended for use by analog circuits

For full details please see the schematic (at the end of this document) and associated layout files (available from the Clockworks website).

It is operated from a 12V supply via a standard 2.1mm (center positive) barrel connector or screw terminal block for discrete wire. An input diode is used to protect against reversed input supply. A 5 x 20mm 1.6A slow blow fuse provides a good failsafe against system damage that might occur when developing prototype systems.

Details about the power supply design and its initial testing can be found in the TechNotes section of the Clockworks website¹.

1.2 HOW SUPPLIED

The PWR001 is supplied in two standard configurations:

- PWR001 board only.
- PWR001, 12V supply (choice of North American and Universal AC plug versions for the supply), spare fuse, and two MTA-100 cable assemblies

1.3 SPECIAL VERSIONS

The supplies have a number of through-hole components that can be changed during final assembly to accommodate a number of alternate versions of the basic three output board.

¹ Many of the scope captures included here are from those documents.

1.3.1 INPUT VOLTAGE RANGE

The module can be ordered with an extended input range of 10V to 24V for use where a regulated input supply is not available. A different capacitor for the hold up function is used, please contact Clockworks for more information.

1.3.2 OUTPUT VOLTAGE OPTIONS

The digital 3.3V output can be changed to 5V. For details on the digital output voltage option see the CUI VXO78-1000 series datasheet. The standard board uses the VXO7803-1000 regulator; the VXO7805-1000 regulator can be used for 5V output.

The +/-15V output (@ 300 mA) can be changed to +/- 5V (@ 1 amp) by using the Meanwell NSD10-12D5 module instead.

In both cases the changed output voltages appear on the correct pins of the MTA-100 output connectors and the original pins are removed. For example this board is configured for +/- 5V output:

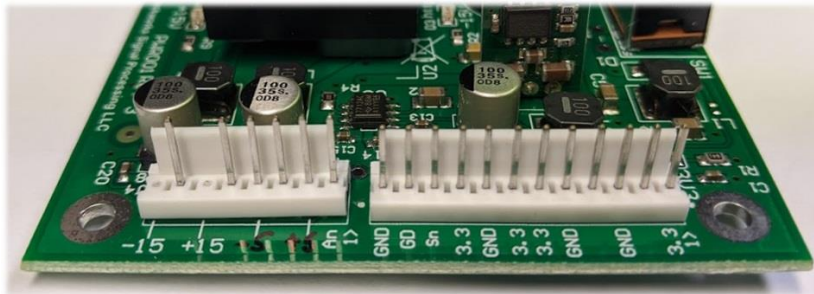

Figure 2 Custom version with +/- 5V output (pins for +/- 15V are removed on the left connector)

1.4 SOFTWARE SUPPORT

The PWR001 module can be controlled by the system host processor, which would use two GPIO lines to interface with the PWR001 module. One GPIO line monitors the power good signal and should cause an interrupt on loss of power. The other GPIO line controls the analog supply. No special software is needed, though the power fail signal should be connected as an NMI to ensure minimal delay in reacting to the loss of power.

For systems without a host processor, the analog enable line should be jumpered low. The power fail signal can be used to directly control any available hardware muting functions.

1.5 INPUT POWER REQUIREMENTS

Under full rated load the board provides 13W of power. With typical regulator efficiency that corresponds to about 16W of input power, or 1.3 Amps for a 12V supply.

The supply design includes a 10,000 uF electrolytic capacitor at the input² and during a cold start situation the external supply will see a brief current spike that lasts for 1 msec and peaks at about 14A. Some small 12V supplies will trip with a load current like that and shut themselves off for a few seconds, during which time the cap discharges.

The Clockworks 12V supply in the kit version has been tested and found to not have issues with startup.

2 CONNECTOR & MECHANICAL INFORMATION

2.1 INPUT CONNECTORS

The input barrel connector, a CUI PJ-050AH, is configured center positive. The input voltage should nominally be 12V, but the supply can operate with 10 – 13V (higher if the holdup cap is switched to a 35V unit).

Alternately the Phoenix Contact 1935161 (5 mm centers) terminal block can be used with wire sizes from 14 AWG to 26 AWG.

2.2 OUTPUT CONNECTORS

There are two output connectors for power, one conforms to the 12 pin SignalBlox standard for digital power and the other the 8 pin standard for analog power. Both are from the TE³ MTA-100 series of connectors, part numbers 1-640454-2 and 640454-8⁴. The mating part numbers (for closed end style) are 4-643813-2 and 3-643813-8. These are designed for 22AWG stranded wire, which is the largest wire size supported with MTA-100 connectors.

Table 1 and Table 2 show the pin assignments as well as the normal wire color used in the cable assemblies provided by Clockworks. For more information on the Clockworks cable assemblies look up part numbers CA002 (12 pin) and CA001 (8 pin).

² That cap is there as a simplistic/low cost way to hold up the outputs to allow analog outputs to be gracefully muted during an unexpected loss of power. It also provides some filtering of the 12V supply, though its higher ESR/ESL doesn't help for high frequency noise.

³ Formerly Tyco Electronics.

⁴ These have a tab to ensure alignment when used with the mating connector with tabs. It does not have the locking ramp as extensive force is needed to unmate the connectors if that was used.

Table 1 : 12 pin digital power connector

Pin	Signal	Wire color
1	+3.3STDBY	purple
2	NC (+5)	red
3	GND	black
4	GND	black
5	NC (+5)	red
6	+3.3	orange
7	+3.3	orange
8	GND	black
9	+3.3	orange
10	NC (DIGPOWERn)	green
11	PWRGOOD	grey
12	GND	black

On the PWR001 module there is no +5V digital supply so pins 2 and 5 are no connects (NC), shaded blue in the above table.

There is only one 3.3V supply and it powers both the +3.3STDBY and +3.3 pins. This also means the DIGIPOWERn signal is not connected, since there is no secondary digital supply to control.

Table 2 : 8 pin analog power connector

Pin	Signal	Wire color
1	ANAPOWERn	green
2	NC (+5)	pink ⁵ (or brown)
3	GND	black
4	NC (-5)	white
5	GND	black
6	+15	yellow
7	GND	black
8	-15	blue

On the PWR001 module there is no +/- 5V analog supply so pins 2 and 4 are no connects (NC), shaded blue in the above table.

To enable the +/- 15V output the ANAPOWERn pin should be pulled low. The pin may driven by a OC output or an active output up to 5V. It will float to 3.3V. Input current is -0.25 mA when pulled low.

3 REGULATOR INFORMATION

The use of standard regulator modules allows the characteristics to be determined from their datasheets.⁶ To save fishing around for those we've copied in some of the information to here.

Please note the maximum C values that are suggested. The PWR001 module has 100 uF on each output, and that should be subtracted from the numbers provided here.

3.1 MEANWELL NDS-10D15 (+/- 15V)

- Voltage tolerance: +/-2.5%
- Line regulation: +/-1%
- Load regulation: +/- 1%
- Max C: 1000 uF
- Max input current: 1.4 A

⁵ Pink is an uncommon color so brown is used for this when pink is unavailable.

⁶ OK, try not to laugh...power supply datasheets are all notoriously lacking in helpful information about how they might work in real circuits.

3.2 CUI VXO7803-1000 (3.3V)

- Voltage tolerance: +/-2% (typ), +/-4% max
- Line regulation: +/-0.2% (typ), +/-0.4% max
- Load regulation: +/-0.4% (typ), +/-0.6% max
- Max C: 680 uF

4 POWER SEQUENCING

Additional details can be found in TecNote TN002, available on the Clockworks website.

The supply voltages all ramp to their final voltages in under 20 msec and the power good signal becomes active 70 msec later, see Figure 3. In that capture the analog enable is jumpered low. The 3.3V supply starts up in a time comparable to the +/-15V.

Load conditions will affect these numbers, and for full details the regulator datasheets should be reviewed.

The power good signal indicates the status of input power, not the voltage at the output of the regulators. If a load short is present the power good signal will still activate.

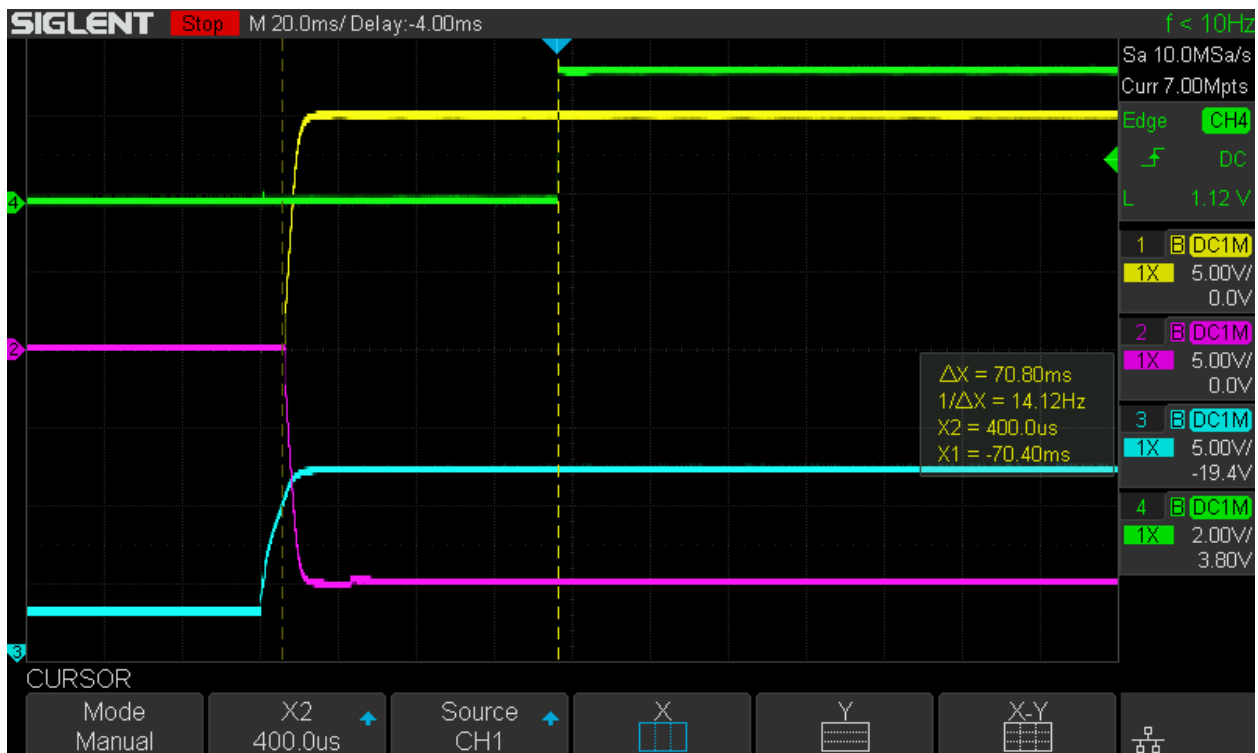

Figure 3 +15V (ch1) Yellow, -15V (ch2) Magenta, 12V in (ch3) Blue, PowerGood (ch4) Green

The amount of holdup time depends on the load. The next example, Figure 4 shows the power off timing with around 7.5 watts of loading. This is for a hard power off. If the input 12V supply decays slowly this can add to the time, though as was demonstrated in TN002 it can also slightly degrade the time as the analog regulators start collapsing but the voltage supervisor has not tripped yet.

With a 12W total load holdup time is around 12 msec. System designs should assume that less than 10 msec is available, though in practice with less than full loads plus normal distributed filter capacitance on the supply rails times should exceed this number.

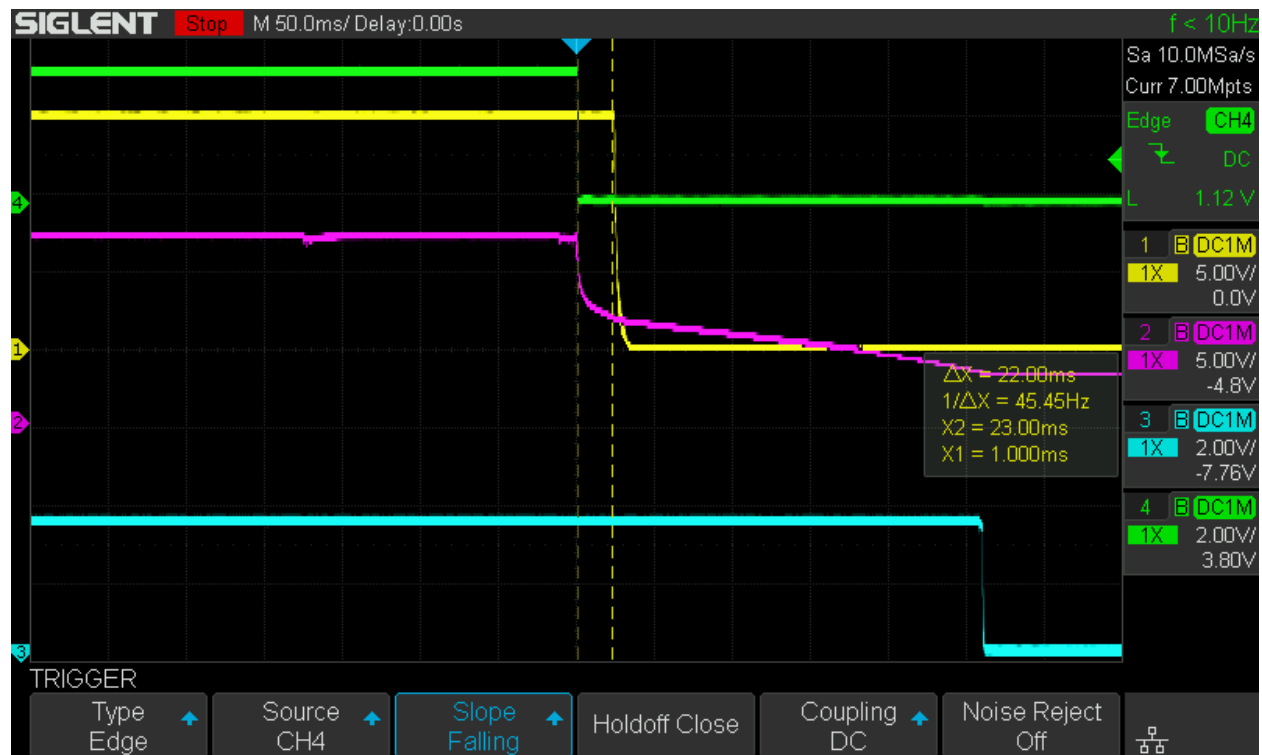
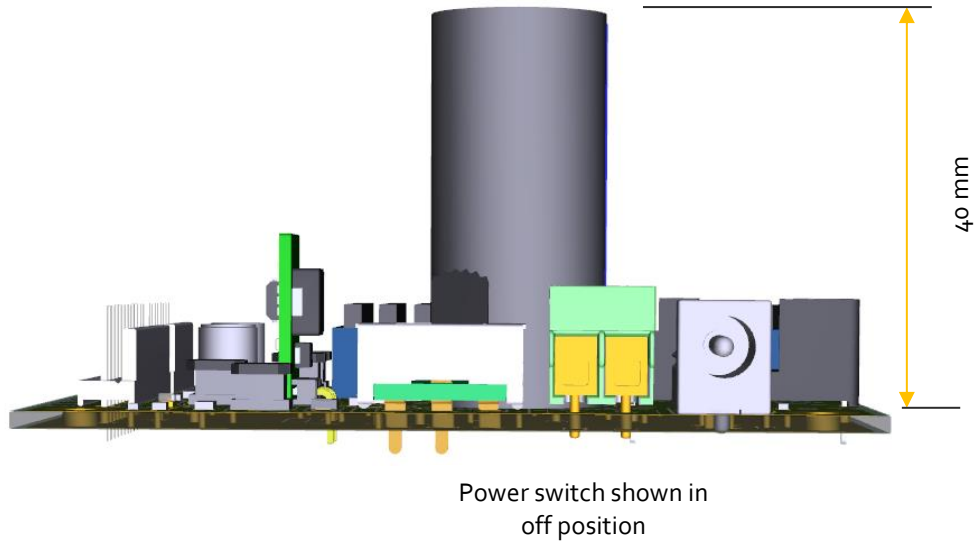
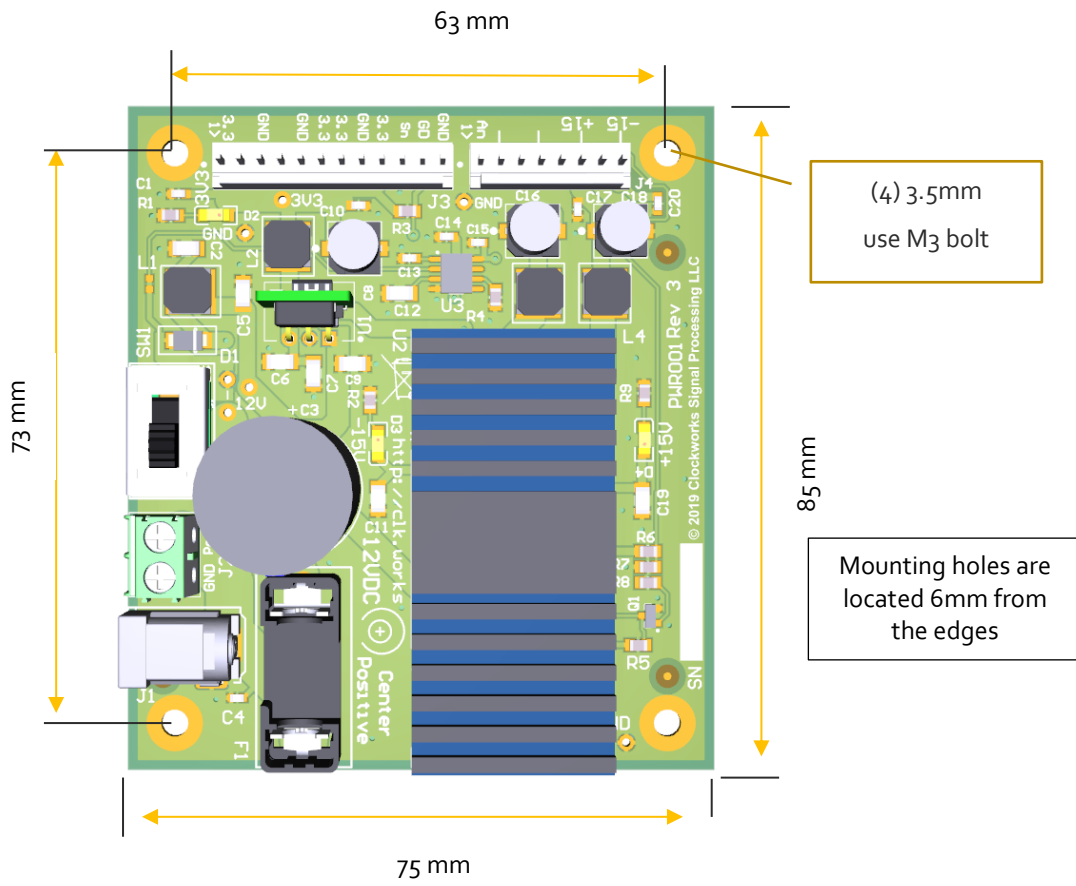

Figure 4 Switched to off. +15V (ch1) Yellow, -12V input (ch2) Magenta, 3.3V (ch3) Blue, PowerGood (ch4) Green

4.1 MECHANICAL

The 4 mounting holes are connected to the ground plane. The tallest component (the hold-up capacitor) top is 40mm over the board. The switch leads protrude 3mm below the board. The PCB is standard .062 (1.6mm) thickness.

Assuming typical efficiencies for a 12V supply input, the board is calculated to dissipate about 3W of power. No special cooling considerations should be needed, though it should not be placed in the airpath of other system components that create heat.



The working temperature of the regulator modules is specified as -25 to +70C. The other components on the board work across a wider range. OTOH heat is the general enemy of long electronics life so placing the supply where it's not next to other hot components as well as can have some natural convective flow is desirable.

5 DESIGN CONSIDERATIONS

The supply board uses a 10 uH choke and 100 uF capacitor to attenuate the switching noise from the bipolar supply. This filter has a Fc of 5 kHz. With assumed DCR/ESR from the part's datasheets there is a bump in the simulated response around Fc as system Q is > 1, but it was not observed in the measurements.

In actual system additional decoupling capacitors would be used near the loads. However for the switching regulators to retain their load transient response there is the competing desire to minimize load capacitance. The tradeoff is further complicated by the noise spectrum of the regulators having a dependency on the current.

SignalBlox carriers provide additional capacitance, typically an additional 200 uF. Each module (analog or mixed signal) is assumed to place an additional 100 uF on each analog supply, though not all boards use all voltages. This places a typical additional capacitance of 400 – 600 uF on the analog supplies. This lowers Fc to around 2 kHz and the Q is closer to 1.

5.1 MEASURED NOISE

These numbers are from a sample and do not indicate a guarantee of performance. They were measured with resistive loads on the +/-15. TechNote 004 has further details on the regulator noise variations with load current. The + and – outputs were found to have the same noise values.

Measurement bandwidth is 22 kHz. Power was from the 12V AC adapter typically supplied with the board. Some weighted measurements are included to give an idea where the noise is; use of A weighting would be a definite cheat for specifying performance. Actually FFT plots are included later.

Load/Capacitance added	Measurement weighting	RMS noise dBV	RMS noise uV
200 mA/None	-	-89.5	33
200 mA/None	C	-92	25
200 mA/None	A	-95.5	17
200 mA/470 uF	-	-92	25
200 mA/470 uF	C	-92.5	24
200 mA/470 uF	A	-102	8
45 mA/None	-	-91	28
45 mA/470 uF	-	-92	25

6 GETTING STARTED WITH THE MODULE

In the kit configuration the board is supplied with a 12V power supply and 8 pin and 12 pin MTA-100 cable assemblies. Connect the two MTA-100 cables to the board and your device. Ensure that the pins are lined up; there are polarizing tabs but enough force will break them off. Don't do that.

Make sure the power switch is in the off position.

Plug the 12 V supply in to the barrel connector and the plug the wall wart in to the AC power.

Flip the switch to the on position. The 3.3V LED should illuminate. Enable the analog supplies from your target board (i.e. pull the ANAPOWERn low, OK to ground it for always on). The +15 and -15V LEDs should illuminate.

Verify your load is receiving the correct power. If one or more of the LEDs fails to light your load may be shorting the supply rail. If all of the LEDs fail to come on verify the 12V supply is operating and check that the fuse has not blown. There is also a 12V test point on the PCB near the power switch.

6.1 OTHER THINGS

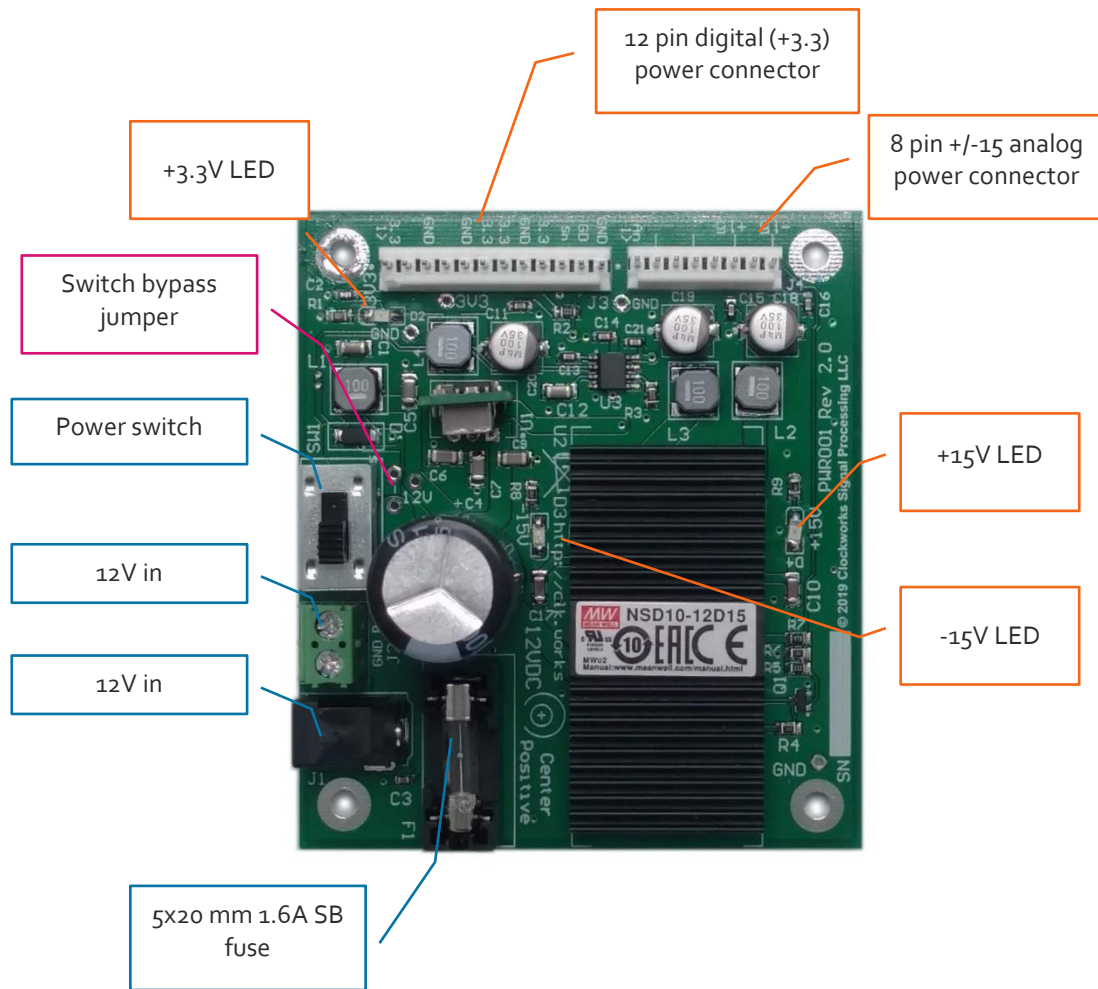

Figure 5 Board feature locations

There are a pair of jumper holes next to the switch. If the switch needs to be disabled to prevent accidental system shut off, a small wire jumper can be soldered in to the two holes next to the switch.

6.2 +/-15 SUPPLY NOISE

TN001 investigated the impact of the +/- 15V supply noise on actual op-amp circuits. The spectrum here are the outputs of the supply under different current loads and with and without 470 uF of additional load capacitance. Both the positive and negative outputs are captured, though as can be seen in the plots they are basically the same.

All plots are 16K point FFTs with 16 averages. The noise in the 60-70 kHz range is background noise on the bench and not part of the supply output. Vertical axis is in dBV.

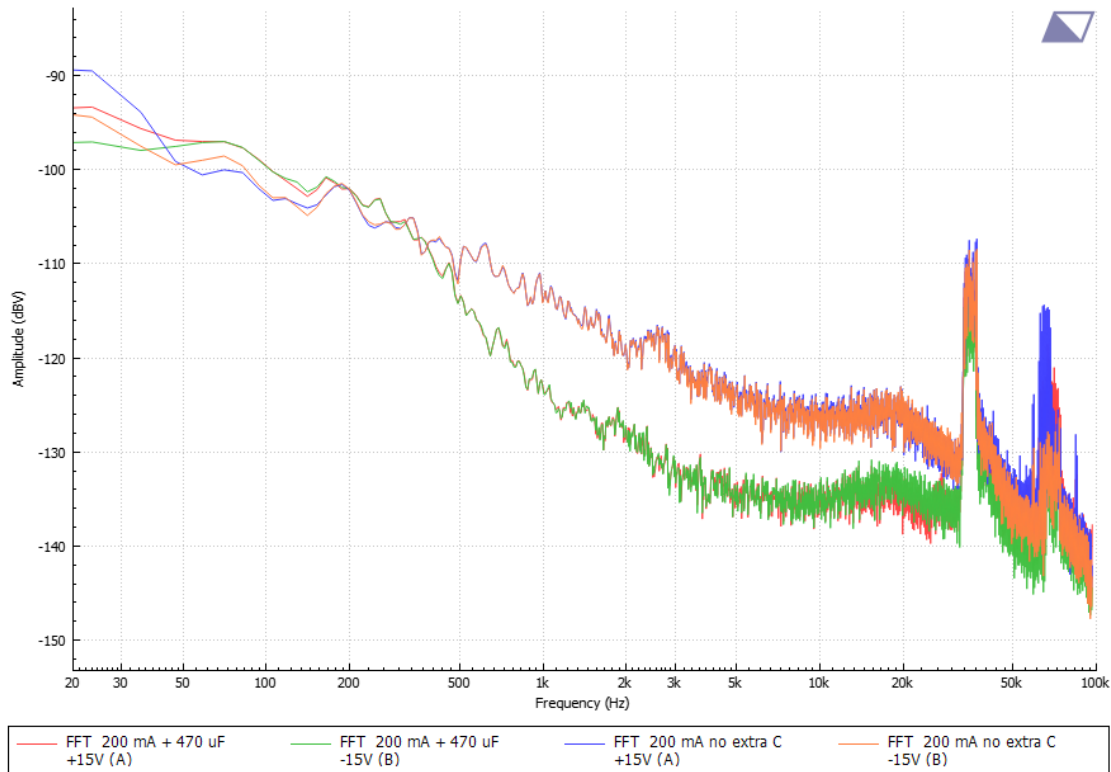

Figure 6 200 mA load showing effect of adding 470 uF on noise spectrum. Total noise in the audio band (22 kHz BW) reduced 2.5 dB.

While the switching frequencies of the supply is around 500 kHz (controller is TI TL3843) the control modulation creates frequencies that can fall in the audio band, particularly this is usually observed under light loads. The following plots with 100 mA and 45 mA loads illustrate this.

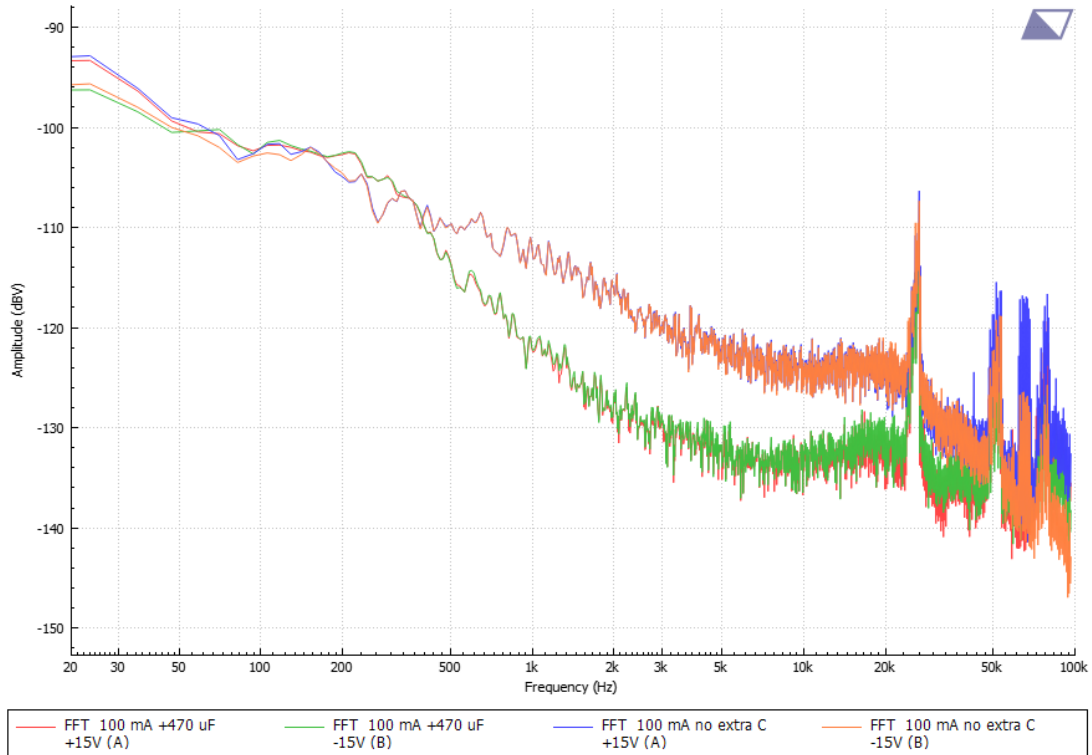

Figure 7 100 mA load showing effect of adding 470 uF on noise spectrum.

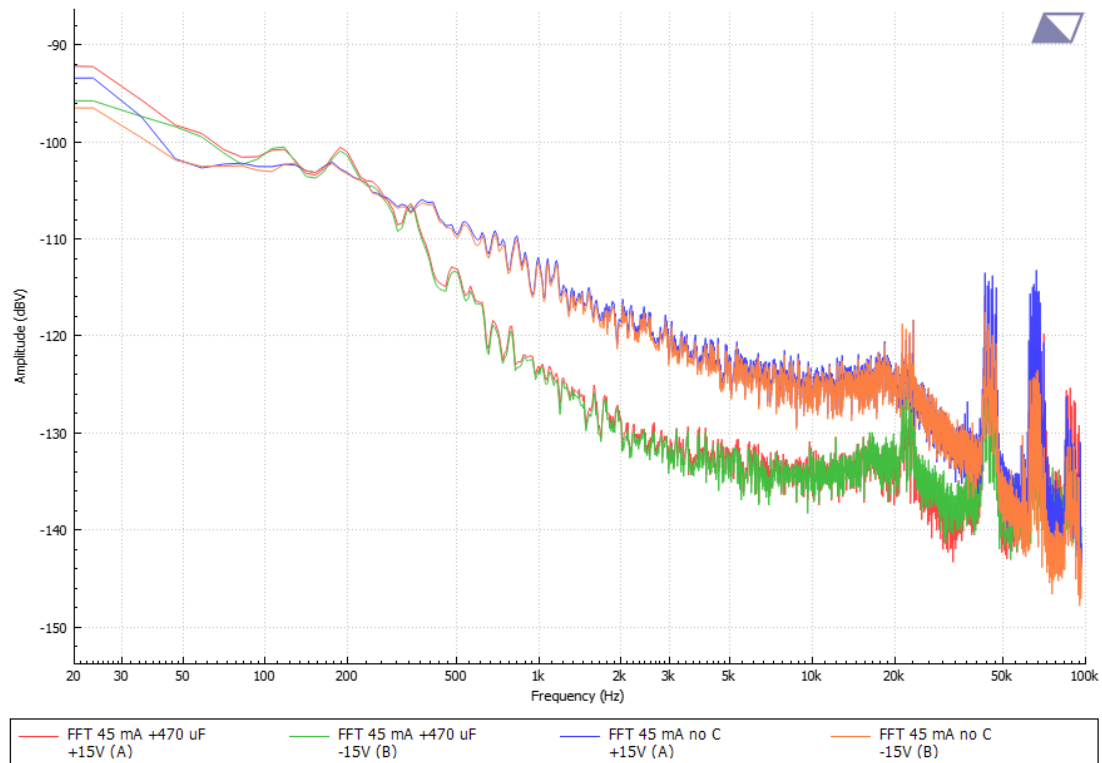

Figure 8 45 mA load showing effect of adding 470 uF on noise spectrum.

PWR001

Triple output supply for SignalBlox systems

+3.3V @ 1A

+/-15V @ 300 mA

12VDC in (9V to 18V Max) @ 1.5 A max.

Power fail detection

max external capacitive load :

3.3V 600 uF

+/-15V 1000 uF

Rev 2:

add LC filters to reduce noise.

fix Meanwell module footprints

move SMT parts to fit everything

fix voltage sensor connections

Rev 3:

add fids, cleanup holes sizes

See PWR002 for a similar design anf the notes there.

LICENSE:

This design is provided under the Creative Commons Attribution-ShareAlike 4.0 International license.

Please see <https://creativecommons.org/licenses/by-sa/4.0/> for details. In summary you agree to:

Attribution — You must give appropriate credit, provide a link to the license, and indicate if changes were made. You may do so in any reasonable manner, but not in any way that suggests the licensor endorses you or your use.

ShareAlike — If you remix, transform, or build upon the material, you must distribute your contributions under the same license as the original.

No additional restrictions — You may not apply legal terms or technological measures that legally restrict others from doing anything the license permits.

If you wish to use this design under different terms you must contact Clockworks Signals Processing.

TRADEMARKS:

SIGNALBLOX and the cube logo are registered trademarks of Clockworks Signal Processing. You may not use nor make any reference to SIGNALBLOX in your derived work and/or any supporting materials without authorization and/or appropriate trademark use license.

SCHEMATIC
PWR001.main.SchDoc



SIGNALBLOX®

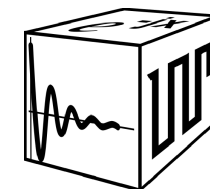

© 2019 Clockworks
Signal Processing LLC

Title **Triple output supply**

Size: A

Number: PWR001

Revision: 3.0

Date: 10/30/2019

Time: 9:24:43 PM

Sheet 1 of 2

File: PWR001.Cover.SchDoc

CLOCKWORKS

Signal Processing

<http://clk.works>

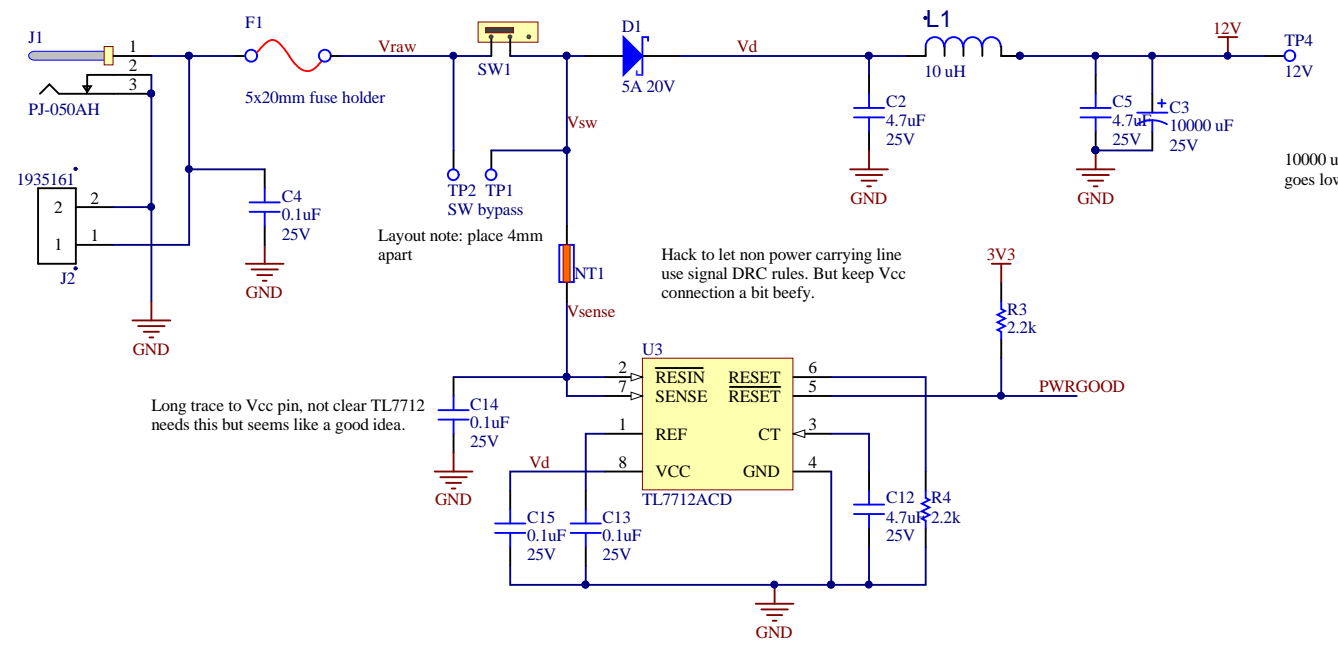

10000 uF to provide holdup time after PWRGOOD goes low on loss of input power.

The large cap on the 12V rail provides the holdup time from power fail to when the supplies may start falling out of regulation. For this supply the 10000uF cap provide about 10 msec of holdup under the worst case loading.

The host processor should, if the hardware supports it, ramp down the signal levels on the output. If that's not possible then asserting MUTE is the next possible step, though obviously a relay type MUTE could create a pop in the output, but this may be the better choice than what the output does when the supply collapses. Or it may not be, it depends on what is driving the output.

Layout note: place 4mm apart

Hack to let non power carrying line use signal DRC rules. But keep Vcc connection a bit beefy.

Long trace to Vcc pin, not clear TL7712 needs this but seems like a good idea.

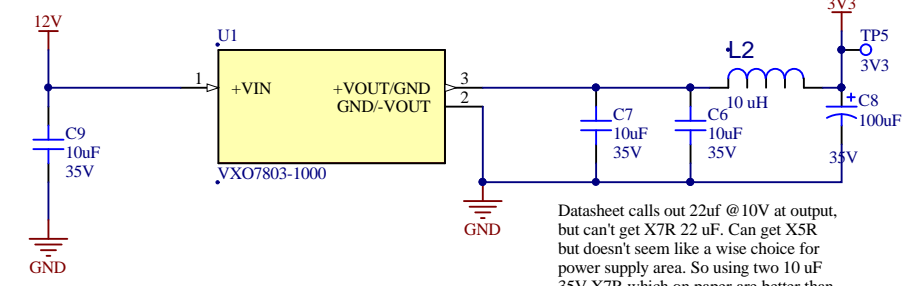
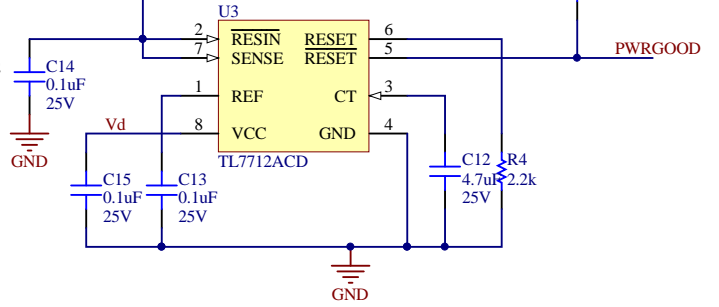

Datasheet calls out 22uF @10V at output, but can't get X7R 22 uF. Can get X5R but doesn't seem like a wise choice for power supply area. So using two 10 uF 35V X7R which on paper are better than one 10V 22uF. Polymer caps might work with a small ceramic in parallel?

Pin 1 is 3.3V standby, but this supply doesn't offer that option so all 3.3V pins are connected together.

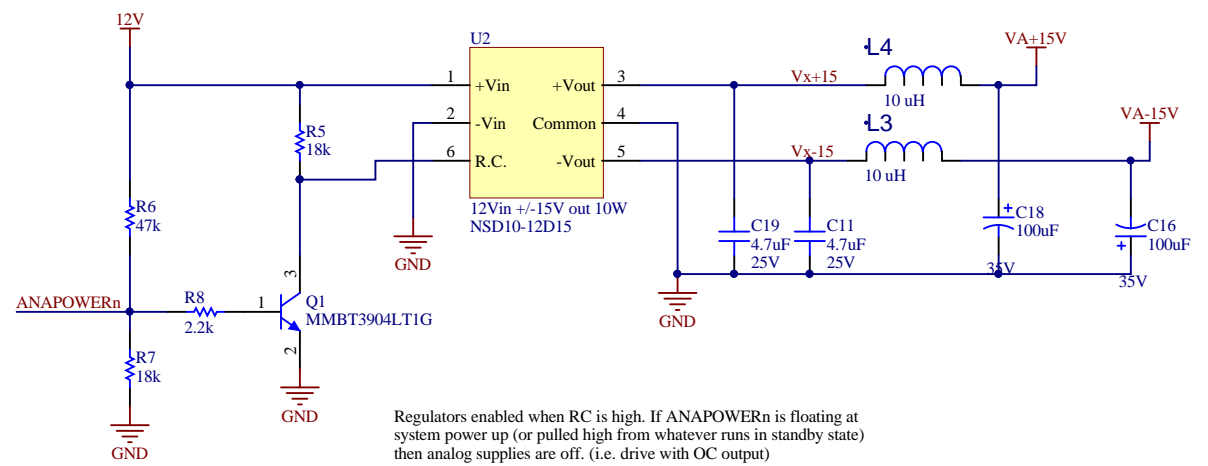

Regulators enabled when RC is high. If ANAPOWERN is floating at system power up (or pulled high from whatever runs in standby state) then analog supplies are off. (i.e. drive with OC output)

Pull ANAPOWERN low to enable analog power supplies

2.2K to limit base current should someone drive the input high

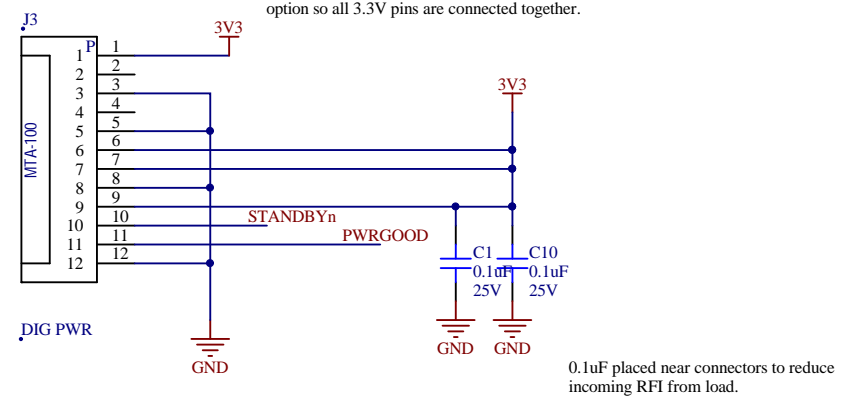
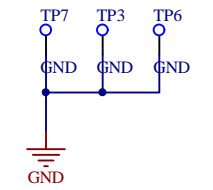

0.1uF placed near connectors to reduce incoming RFI from load.

